



ANTENNA THEORY

ANALYSIS
AND DESIGN

FOURTH EDITION

CONSTANTINE A. BALANIS

WILEY

ANTENNA THEORY

ANTENNA THEORY

ANALYSIS AND DESIGN

FOURTH EDITION

Constantine A. Balanis

WILEY

Cover Image: Courtesy NASA/JPL-Caltech

Copyright © 2016 by John Wiley & Sons, Inc. All rights reserved

Published by John Wiley & Sons, Inc., Hoboken, New Jersey
Published simultaneously in Canada

No part of this publication may be reproduced, stored in a retrieval system, or transmitted in any form or by any means, electronic, mechanical, photocopying, recording, scanning, or otherwise, except as permitted under Section 107 or 108 of the 1976 United States Copyright Act, without either the prior written permission of the Publisher, or authorization through payment of the appropriate per-copy fee to the Copyright Clearance Center, Inc., 222 Rosewood Drive, Danvers, MA 01923, (978) 750-8400, fax (978) 750-4470, or on the web at www.copyright.com. Requests to the Publisher for permission should be addressed to the Permissions Department, John Wiley & Sons, Inc., 111 River Street, Hoboken, NJ 07030, (201) 748-6011, fax (201) 748-6008, or online at <http://www.wiley.com/go/permission>.

Limit of Liability/Disclaimer of Warranty: While the publisher and author have used their best efforts in preparing this book, they make no representations or warranties with respect to the accuracy or completeness of the contents of this book and specifically disclaim any implied warranties of merchantability or fitness for a particular purpose. No warranty may be created or extended by sales representatives or written sales materials. The advice and strategies contained herein may not be suitable for your situation. You should consult with a professional where appropriate. Neither the publisher nor author shall be liable for any loss of profit or any other commercial damages, including but not limited to special, incidental, consequential, or other damages.

For general information on our other products and services or for technical support, please contact our Customer Care Department within the United States at (800) 762-2974, outside the United States at (317) 572-3993 or fax (317) 572-4002.

Wiley also publishes its books in a variety of electronic formats. Some content that appears in print may not be available in electronic formats. For more information about Wiley products, visit our web site at www.wiley.com.

Library of Congress Cataloging-in-Publication Data:

Balanis, Constantine A., 1938–
Modern antenna handbook / Constantine A. Balanis.—4th ed.
p. cm.

Includes index.

ISBN 978-1-118-642060-1 (cloth)

1. Antennas (Electronics) I. Title.

TK7871.6.B354 2016

621.382'4—dc22

2016050162

Printed in the United States of America

10 9 8 7 6 5 4 3 2 1

To the memory of my parents, uncle and aunt

Στη μνήμη των γονέων, του θείου και της θείας μου



Contents

Preface	xiii
About the Companion Website	xix
1 Antennas	1
1.1 Introduction	1
1.2 Types of Antennas	3
1.3 Radiation Mechanism	7
1.4 Current Distribution on a Thin Wire Antenna	15
1.5 Historical Advancement	18
1.6 Multimedia	21
References	22
2 Fundamental Parameters and Figures-of-Merit of Antennas	25
2.1 Introduction	25
2.2 Radiation Pattern	25
2.3 Radiation Power Density	35
2.4 Radiation Intensity	37
2.5 Beamwidth	40
2.6 Directivity	41
2.7 Numerical Techniques	55
2.8 Antenna Efficiency	60
2.9 Gain, Realized Gain	61
2.10 Beam Efficiency	65
2.11 Bandwidth	65
2.12 Polarization	66
2.13 Input Impedance	75
2.14 Antenna Radiation Efficiency	79
2.15 Antenna Vector Effective Length and Equivalent Areas	81
2.16 Maximum Directivity and Maximum Effective Area	86
2.17 Friis Transmission Equation and Radar Range Equation	88
2.18 Antenna Temperature	96
2.19 Multimedia	100
References	103
Problems	105

3	Radiation Integrals and Auxiliary Potential Functions	127
3.1	Introduction	127
3.2	The Vector Potential \mathbf{A} for an Electric Current Source \mathbf{J}	128
3.3	The Vector Potential \mathbf{F} for A Magnetic Current Source \mathbf{M}	130
3.4	Electric and Magnetic Fields for Electric (\mathbf{J}) and Magnetic (\mathbf{M}) Current Sources	131
3.5	Solution of the Inhomogeneous Vector Potential Wave Equation	132
3.6	Far-Field Radiation	136
3.7	Duality Theorem	137
3.8	Reciprocity and Reaction Theorems	138
	References	143
	Problems	143
4	Linear Wire Antennas	145
4.1	Introduction	145
4.2	Infinitesimal Dipole	145
4.3	Small Dipole	155
4.4	Region Separation	158
4.5	Finite Length Dipole	164
4.6	Half-Wavelength Dipole	176
4.7	Linear Elements Near or On Infinite Perfect Electric Conductors (PEC), Perfect Magnetic Conductors (PMC) and Electromagnetic Band-Gap (EBG) Surfaces	179
4.8	Ground Effects	203
4.9	Computer Codes	216
4.10	Multimedia	216
	References	218
	Problems	220
5	Loop Antennas	235
5.1	Introduction	235
5.2	Small Circular Loop	236
5.3	Circular Loop of Constant Current	250
5.4	Circular Loop with Nonuniform Current	259
5.5	Ground and Earth Curvature Effects for Circular Loops	268
5.6	Polygonal Loop Antennas	269
5.7	Ferrite Loop	270
5.8	Mobile Communication Systems Applications	272
5.9	Multimedia	272
	References	275
	Problems	277
6	Arrays: Linear, Planar, and Circular	285
6.1	Introduction	285
6.2	Two-Element Array	286
6.3	N -Element Linear Array: Uniform Amplitude and Spacing	293
6.4	N -Element Linear Array: Directivity	312
6.5	Design Procedure	318
6.6	N -Element Linear Array: Three-Dimensional Characteristics	319
6.7	Rectangular-to-Polar Graphical Solution	322

6.8	<i>N</i> -Element Linear Array: Uniform Spacing, Nonuniform Amplitude	323
6.9	Superdirectivity	345
6.10	Planar Array	348
6.11	Design Considerations	360
6.12	Circular Array	363
6.13	Multimedia	367
	References	367
	Problems	368
7	Antenna Synthesis and Continuous Sources	385
7.1	Introduction	385
7.2	Continuous Sources	386
7.3	Schelkunoff Polynomial Method	387
7.4	Fourier Transform Method	392
7.5	Woodward-Lawson Method	398
7.6	Taylor Line-Source (Tschebyscheff-Error)	404
7.7	Taylor Line-Source (One-Parameter)	408
7.8	Triangular, Cosine, and Cosine-Squared Amplitude Distributions	415
7.9	Line-Source Phase Distributions	416
7.10	Continuous Aperture Sources	417
7.11	Multimedia	420
	References	420
	Problems	421
8	Integral Equations, Moment Method, and Self and Mutual Impedances	431
8.1	Introduction	431
8.2	Integral Equation Method	432
8.3	Finite Diameter Wires	439
8.4	Moment Method Solution	448
8.5	Self-Impedance	455
8.6	Mutual Impedance Between Linear Elements	463
8.7	Mutual Coupling in Arrays	474
8.8	Multimedia	480
	References	480
	Problems	482
9	Broadband Dipoles and Matching Techniques	485
9.1	Introduction	485
9.2	Biconical Antenna	487
9.3	Triangular Sheet, Flexible and Conformal Bow-Tie, and Wire Simulation	492
9.4	Vivaldi Antenna	496
9.5	Cylindrical Dipole	500
9.6	Folded Dipole	505
9.7	Discone and Conical Skirt Monopole	512
9.8	Matching Techniques	513
9.9	Multimedia	523
	References	524
	Problems	525

10	Traveling Wave and Broadband Antennas	533
10.1	Introduction	533
10.2	Traveling Wave Antennas	533
10.3	Broadband Antennas	549
10.4	Multimedia	580
	References	580
	Problems	582
11	Frequency Independent Antennas, Antenna Miniaturization, and Fractal Antennas	591
11.1	Introduction	591
11.2	Theory	592
11.3	Equiangular Spiral Antennas	593
11.4	Log-Periodic Antennas	598
11.5	Fundamental Limits of Electrically Small Antennas	614
11.6	Antenna Miniaturization	619
11.7	Fractal Antennas	627
11.8	Multimedia	633
	References	633
	Problems	635
12	Aperture Antennas	639
12.1	Introduction	639
12.2	Field Equivalence Principle: Huygens' Principle	639
12.3	Radiation Equations	645
12.4	Directivity	648
12.5	Rectangular Apertures	648
12.6	Circular Apertures	667
12.7	Design Considerations	675
12.8	Babinet's Principle	680
12.9	Fourier Transforms in Aperture Antenna Theory	684
12.10	Ground Plane Edge Effects: The Geometrical Theory of Diffraction	702
12.11	Multimedia	707
	References	707
	Problems	709
13	Horn Antennas	719
13.1	Introduction	719
13.2	<i>E</i> -Plane Sectoral Horn	719
13.3	<i>H</i> -Plane Sectoral Horn	733
13.4	Pyramidal Horn	743
13.5	Conical Horn	756
13.6	Corrugated Horn	761
13.7	Aperture-Matched Horns	766
13.8	Multimode Horns	769
13.9	Dielectric-Loaded Horns	771
13.10	Phase Center	773
13.11	Multimedia	774
	References	775
	Problems	778

14	Microstrip and Mobile Communications Antennas	783
14.1	Introduction	783
14.2	Rectangular Patch	788
14.3	Circular Patch	815
14.4	Quality Factor, Bandwidth, and Efficiency	823
14.5	Input Impedance	826
14.6	Coupling	827
14.7	Circular Polarization	830
14.8	Arrays and Feed Networks	832
14.9	Antennas for Mobile Communications	837
14.10	Dielectric Resonator Antennas	847
14.11	Multimedia	858
	References	862
	Problems	867
15	Reflector Antennas	875
15.1	Introduction	875
15.2	Plane Reflector	875
15.3	Corner Reflector	876
15.4	Parabolic Reflector	884
15.5	Spherical Reflector	920
15.6	Multimedia	923
	References	923
	Problems	925
16	Smart Antennas	931
16.1	Introduction	931
16.2	Smart-Antenna Analogy	931
16.3	Cellular Radio Systems Evolution	933
16.4	Signal Propagation	939
16.5	Smart Antennas' Benefits	942
16.6	Smart Antennas' Drawbacks	943
16.7	Antenna	943
16.8	Antenna Beamforming	946
16.9	Mobile Ad hoc Networks (MANETs)	960
16.10	Smart-Antenna System Design, Simulation, and Results	964
16.11	Beamforming, Diversity Combining, Rayleigh-Fading, and Trellis-Coded Modulation	972
16.12	Other Geometries	975
16.13	Multimedia	976
	References	976
	Problems	980
17	Antenna Measurements	981
17.1	Introduction	981
17.2	Antenna Ranges	982
17.3	Radiation Patterns	1000
17.4	Gain Measurements	1003
17.5	Directivity Measurements	1010

17.6	Radiation Efficiency	1012
17.7	Impedance Measurements	1012
17.8	Current Measurements	1014
17.9	Polarization Measurements	1014
17.10	Scale Model Measurements	1019
	References	1024
Appendix I:	$f(x) = \frac{\sin(x)}{x}$	1027
Appendix II:	$f_N(x) = \left \frac{\sin(Nx)}{N \sin(x)} \right $ $N = 1, 3, 5, 10, 20$	1029
Appendix III:	Cosine and Sine Integrals	1031
Appendix IV:	Fresnel Integrals	1033
Appendix V:	Bessel Functions	1035
Appendix VI:	Identities	1041
Appendix VII:	Vector Analysis	1045
Appendix VIII:	Method of Stationary Phase	1055
Appendix IX:	Television, Radio, Telephone, and Radar Frequency Spectrums	1061
Index		1065



Preface

The fourth edition of *Antenna Theory* is designed to meet the needs of electrical engineering and physics students at the senior undergraduate and beginning graduate levels, and those of practicing engineers. The text presumes that the students have knowledge of basic undergraduate electromagnetic theory, including Maxwell's equations and the wave equation, introductory physics, and differential and integral calculus. Mathematical techniques required for understanding some advanced topics in the later chapters are incorporated in the individual chapters or are included as appendices.

The book, since its first edition in 1982 and subsequent two editions in 1997 and 2005, has been a pacesetter and trail blazer in updating the contents to keep abreast with advancements in antenna technology. This has been accomplished by:

- Introducing new topics
- Originating innovative features and multimedia to animate, visualize, illustrate and display radiation characteristics
- Providing design equations, procedures and associate software

This edition is no exception, as many new topics and features have been added. In particular:

- New sections have been introduced on:
 1. Flexible and conformal bowtie
 2. Vivaldi antenna
 3. Antenna miniaturization
 4. Antennas for mobile communications
 5. Dielectric resonator antennas
 6. Scale modeling
- Additional MATLAB and JAVA programs have been developed.
- Color and gray scale figures and illustrations have been developed to clearly display and visualize antenna radiation characteristics.
- A companion website has been structured by the publisher which houses the MATLAB programs, JAVA-based applets and animations, Power Point notes, and JAVA-based interactive questionnaires. A solutions manual is available only for the instructors that adopt the book as a classroom text.
- Over 100 additional end-of-chapter problems have been included.

While incorporating the above new topics and features in the current edition, the book maintained all of the attractive features of the first three additions, especially the:

- Three-dimensional graphs to display the radiation characteristics of antennas. This feature was hailed, at the time of its introduction, as innovative and first of its kind addition in a textbook on antennas.

- Advanced topics, such as a chapter on *Smart Antennas* and a section on *Fractal Antennas*.
- Multimedia:
 1. Power Point notes
 2. MATLAB programs
 3. FORTRAN programs
 4. JAVA-based animations
 5. JAVA-based applets
 6. JAVA-based end-of-the-chapter questionnaires

The book's main objective is to introduce, in a unified manner, the fundamental principles of antenna theory and to apply them to the analysis, design, and measurements of antennas. Because there are so many methods of analysis and design and a plethora of antenna structures, applications are made to some of the most basic and practical configurations, such as linear dipoles; loops; arrays; broadband, and frequency-independent antennas; aperture antennas; horn antennas; microstrip antennas; and reflector antennas.

A tutorial chapter on Smart Antennas is included to introduce the student in a technology that will advance antenna theory and design, and revolutionize wireless communications. It is based on antenna theory, digital signal processing, networks and communications. MATLAB simulation software has also been included, as well as a plethora of references for additional reading.

Introductory material on analytical methods, such as the Moment Method and Fourier transform (spectral) technique, is also included. These techniques, together with the fundamental principles of antenna theory, can be used to analyze and design almost any antenna configuration. A chapter on antenna measurements introduces state-of-the-art methods used in the measurements of the most basic antenna characteristics (pattern, gain, directivity, radiation efficiency, impedance, current, and polarization) and updates progress made in antenna instrumentation, antenna range design, and scale modeling. Techniques and systems used in near- to far-field measurements and transformations are also discussed.

A sufficient number of topics have been covered, some for the first time in an undergraduate text, so that the book will serve not only as a text but also as a reference for the practicing and design engineer and even the amateur radio buff. These include design procedures, and associated computer programs, for Yagi–Uda and log-periodic arrays, horns, and microstrip patches; synthesis techniques using the Schelkunoff, Fourier transform, Woodward–Lawson, Tschebyscheff, and Taylor methods; radiation characteristics of corrugated, aperture-matched, and multimode horns; analysis and design of rectangular and circular microstrip patches; and matching techniques such as the binomial and Tschebyscheff. Also new sections have been introduced on flexible & conformal bowtie and Vivaldi antennas in Chapter 9, antenna miniaturization in Chapter 11 and expanded scale modeling in Chapter 17.

Chapter 14 has been expanded to include antennas for Mobile Communications. In particular, this new section includes basic concepts and design equations for the Planar Inverted-F Antenna (PIFA), Slot Antenna, Inverted-F Antenna (IFA), Multiband U-type Slot Antenna, and Dielectric Resonator Antennas (DRAs). These are popular internal antennas for mobile devices (smart phones, laptops, pads, tablets, etc.). A MATLAB computer program, referred to as **DRA_Analysis_Design**, has been developed to analyze the resonant frequencies of Rectangular, Cylindrical, Hemicylindrical, and Hemispherical DRAs using TE and TM modal cavity techniques by modeling the walls as PMCs. Hybrid modes are used to analyze and determine the resonant frequencies and quality factor (Q) of the Cylindrical DRA. The MATLAB program **DRA_Analysis_Design** has the capability, using a nonlinear solver, to design (i.e., find the Q , range of values for the dielectric constant, and finally the dimensions of the Cylindrical DRA) once the hybrid mode ($TE_{01\delta}$, $TM_{01\delta}$ or $HE_{11\delta}$), fractional bandwidth (BW, in %), VSWR and resonant frequency (f_r , in GHz) are specified. A detailed procedure to follow the design is outlined in Section 14.10.4.

The text contains sufficient mathematical detail to enable the average undergraduate electrical engineering and physics students to follow, without difficulty, the flow of analysis and design. A certain amount of analytical detail, rigor, and thoroughness allows many of the topics to be traced to their origin. My experiences as a student, engineer, and teacher have shown that a text for this course must not be a book of unrelated formulas, and it must not resemble a “cookbook.” This book begins with the most elementary material, develops underlying concepts needed for sequential topics, and progresses to more advanced methods and system configurations. Each chapter is subdivided into sections or subsections whose individual headings clearly identify the antenna characteristic(s) discussed, examined, or illustrated.

A distinguished feature of this book is its three-dimensional graphical illustrations from the first edition, which have been expanded and supplemented in the second, third and fourth editions. In the past, antenna texts have displayed the three-dimensional energy radiated by an antenna by a number of separate two-dimensional patterns. With the advent and revolutionary advances in digital computations and graphical displays, an additional dimension has been introduced for the first time in an undergraduate antenna text by displaying the radiated energy of a given radiator by a single three-dimensional graphical illustration. Such an image, formed by the graphical capabilities of the computer and available at most computational facilities, gives a clear view of the energy radiated in all space surrounding the antenna. In this fourth edition, almost all of the three-dimensional amplitude radiation patterns, along with many two-dimensional graphs, are depicted in color and gray-scale. This is a new and pacesetting feature adopted, on a large scale, in this edition. It is hoped that this will lead to a better understanding of the underlying principles of radiation and provide a clearer visualization of the pattern formation in all space.

In addition, there is an abundance of general graphical illustrations, design data, references, and an expanded list of end-of-the chapter problems. Many of the principles are illustrated with examples, graphical illustrations, and physical arguments. Although students are often convinced that they understand the principles, difficulties arise when they attempt to use them. An example, especially a graphical illustration, can often better illuminate those principles. As they say, “a picture is worth a thousand words.”

Numerical techniques and computer solutions are illustrated and encouraged. A number of MATLAB computer programs are included in the publisher’s website for the book. Each program is interactive and prompts the user to enter the data in a sequential manner. Some of these programs are translations of the FORTRAN ones that were included in the first and second editions. However, many new ones have been developed. Every chapter, other than Chapters 3 and 17, has at least one MATLAB computer program; some have as many as four. The outputs of the MATLAB programs include graphical illustrations and tabulated results. For completeness, the FORTRAN computer programs are also included, although nowadays there is not as much interest in them. The computer programs can be used for analysis and design. Some of them are more of the design type while some of the others are of the analysis type. Associated with each program there is a READ ME file, which summarizes the respective program.

The purpose of the Power Point Lecture Notes is to provide the instructors a copy of the text figures and some of the most important equations of each chapter. They can be used by the instructors in their lectures but may be supplemented with additional narratives. The students can use them to listen to the instructors’ lectures, without having to take detailed notes, but can supplement them in the margins with annotations from the lectures. Each instructor will use the notes in a different way.

The Interactive Questionnaires are intended as reviews of the material in each chapter. The student can use them to review for tests, exams, and so on. For each question, there are three possible answers, but only one is correct. If the reader chooses one of them and it the correct answer, it will so indicate. However, if the chosen answer is the wrong one, the program will automatically indicate the correct answer. An explanation button is provided, which gives a short narrative on the correct answer or indicates where in the book the correct answer can be found.

The Animations can be used to illustrate some of the radiation characteristics, such as amplitude patterns, of some antenna types, like line sources, dipoles, loops, arrays, and horns. The Applets cover more chapters and can be used to examine some of the radiation characteristics (such as amplitude patterns, impedance, bandwidth, etc.) of some of the antennas. This can be accomplished very rapidly without having to resort to the MATLAB programs, which are more detailed.

For course use, the text is intended primarily for a two-semester (or two- or three-quarter) sequence in antenna theory. The first course should be given at the senior undergraduate level, and should cover most of the material in Chapters 1 through 7, and some sections of Chapters 14, 16 and 17. The material in Chapters 8 through 16 should be covered in detail in a beginning graduate-level course. Selected chapters and sections from the book can be covered in a single semester, without loss of continuity. However, it is essential that most of the material in Chapters 2 through 6 be covered in the first course and before proceeding to any more advanced topics. To cover all the material of the text in the proposed time frame would be, in some cases, an ambitious and challenging task. Sufficient topics have been included, however, to make the text complete and to give the teacher the flexibility to emphasize, deemphasize, or omit sections or chapters. Some of the chapters and sections can be omitted without loss of continuity.

In the entire book, an $e^{j\omega t}$ time variation is assumed, and it is suppressed. The International System of Units, which is an expanded form of the rationalized MKS system, is used in the text. In some cases, the units of length are in meters (or centimeters) and in feet (or inches). Numbers in parentheses () refer to equations, whereas those in brackets [] refer to references. For emphasis, the most important equations, once they are derived, are boxed. In some of the basic chapters, the most important equations are summarized in tables.

I will like to acknowledge the invaluable suggestions from all those that contributed to the first three additions of the book, too numerous to mention here. Their names and contributions are stated in the respective editions. It is my pleasure to acknowledge the suggestions of the reviewers for the fourth edition: Dr. Stuart A. Long of the University of Houston, Dr. Leo Kempel of Michigan State University, and Dr. Cynthia M. Furse of the University of Utah. There have been other contributors to this edition, and their contributions are valued and acknowledged. Many graduate and undergraduate students at Arizona State University have written and verified most of the MATLAB computer programs; some of these programs were translated from FORTRAN, which appeared in the first three editions and updated for the fourth edition. However some new MATLAB and JAVA programs have been created, which are included for the first time in the fourth edition. I am indebted to Dr. Alix Rivera-Albino who developed with special care all of the color and gray scale figures and illustrations for the fourth edition and contributed to the manuscript and figures for the Vivaldi and mobile antennas. The author also acknowledges Dr. Razib S. Shishir of Intel, formerly of Arizona State University, for the JAVA-based software for the third edition, including the Interactive Questionnaires, Applets and Animations. These have been supplemented with additional ones for the fourth edition. Many thanks to Dr. Stuart A. Long, from the University of Houston, for reviewing the section on DRAs and Dr. Christos Christodoulou, from the University of New Mexico, for reviewing the manuscript on antennas for mobile devices, Dr. Peter J. Bevelacqua of Google for material related to planar antennas for mobile units, Dr. Arnold Mckinley of University College London (formerly with the Australian National University) for information and computer program related to nonuniform loop antennas, Dr. Steven R. Best of Mitre Corporation for figures on the folded spherical helix, Dr. Edward J. Rothwell, from Michigan State University, for antenna miniaturization information, Dr. Seong-Ook Park of the Korea Advanced Institute of Science and Technology (KAIST), for the photo and permission of the U-slot antenna, and Dr. Yahia Antar and Dr. Jawad Y. Siddiqui, both from the Royal Military College of Canada, for information related to cylindrical DRAs. I would also like to thank Craig R. Birtcher, and my graduate students Dr. Ahmet C. Durgun (now with Intel), Dr. Nafati Aboserwal (now at the University of Oklahoma), Sivaseetharaman Pandi, Mikal Askarian Amiri, Wengang Chen, Saud Saeed and Anuj Modi, all of Arizona State University, for proofreading of the manuscript and many other contributions to the fourth edition.

Special thanks to the companies that contributed photos, illustrations and copyright permissions for the third edition. However, other companies, Samsung, Microsoft and HTC have provided updated photos of their respective smart phones for the fourth edition.

During my 50+ year professional career, I have made many friends and professional colleagues. The list is too long to be included here, as I fear that I may omit someone. Thank you for your friendship, collegiality and comradery. I will like to recognize George C. Barber, Dennis DeCarlo and the entire membership (members, government agencies and companies) of the Advanced Helicopter Electromagnetics (AHE) Program for the 25 years of interest and support. It has been an unprecedented professional partnership and collaboration. To all my teachers and mentors, thank you. You have been my role models and inspiration.

This journey got started in the middle to the late 1970s, at the early stages of my academic career. Many may speculate why I have chosen to remain as the sole author and steward for so many years, dating back to first edition in 1982 and then through the subsequent three editions of this book and two editions of the *Advanced Engineering Electromagnetics* book. I wanted, as long as I was able to accomplish the tasks, to have the books manifest my own fingerprint and reflect my personal philosophy, methodology and pedagogy. Also I wanted the manuscript to display continuity and consistency, and to control my own destiny, in terms of material to be included and excluded, revisions, deadlines and timelines. Finally, I wanted to be responsible for the contents of the book. In the words of Frank Sinatra, 'I did it my way.' Each edition presented its own challenges, but each time I cherished and looked forward to the mission and venture.

I am also grateful to the staff of John Wiley & Sons, Inc., especially Brett Kurzman, Editor, Alex Castro, Editorial Assistant, and Danielle LaCourciere, Production Editor for this edition. Special thanks to Shikha Sharma, from Aptara, Inc., for supervising the typesetting of the book. Finally I must pay tribute and homage to my family (Helen, Renie, Stephanie, Bill, Pete and Ellie) for their unconditional support, patience, sacrifice, and understanding for the many years of neglect during the completion of all four editions of this book and two editions of the *Advanced Engineering Electromagnetics*. Each edition has been a pleasant experience although a daunting task.

Constantine A. Balanis
Arizona State University
Tempe, AZ



About the Companion Website

There is a student companion website that contains:

- PowerPoint Viewgraphs
- MATLAB Programs
- JAVA Applets
- Animations
- End-of-Chapter Interactive Questionnaires

To access the material on the companion site simply find your unique website redemption code printed on the inside front endpaper of this book. Peel off the sticker and then visit www.wiley.com/go/antennatheory4e to follow the instructions for how to register your pin.

If you have purchased this title as an e-book, Wiley Customer Care will provide your access code for the companion website. Visit <http://support.wiley.com> to request via the “Live Chat” or “Ask A Question” tabs, within 90 days of purchase, and please have your receipt for verification.

This book is also accompanied by a password protected companion website for instructors only. This website contains:

- Power Point Viewgraphs
- MATLAB Programs
- JAVA Applets
- Animations
- End-of-Chapter Interactive Questionnaires
- Solutions Manual

To access the material on the instructor’s website simply visit www.wiley.com/go/instructors.antennatheory4e and follow the instructions for how to register.

CHAPTER 1



Antennas

1.1 INTRODUCTION

An antenna is defined by Webster's Dictionary as "a usually metallic device (as a rod or wire) for radiating or receiving radio waves." The *IEEE Standard Definitions of Terms for Antennas* (IEEE Std 145–1983)* defines the antenna or aerial as "a means for radiating or receiving radio waves." In other words the antenna is the transitional structure between free-space and a guiding device, as shown in Figure 1.1. The guiding device or transmission line may take the form of a coaxial line or a hollow pipe (waveguide), and it is used to transport electromagnetic energy from the transmitting source to the antenna, or from the antenna to the receiver. In the former case, we have a *transmitting* antenna and in the latter a *receiving* antenna.

A transmission-line Thevenin equivalent of the antenna system of Figure 1.1 in the transmitting mode is shown in Figure 1.2 where the source is represented by an ideal generator, the transmission line is represented by a line with characteristic impedance Z_c , and the antenna is represented by a load Z_A [$Z_A = (R_L + R_r) + jX_A$] connected to the transmission line. The Thevenin and Norton circuit equivalents of the antenna are also shown in Figure 2.27. The load resistance R_L is used to represent the conduction and dielectric losses associated with the antenna structure while R_r , referred to as the *radiation resistance*, is used to represent radiation by the antenna. The reactance X_A is used to represent the imaginary part of the impedance associated with radiation by the antenna. This is discussed more in detail in Sections 2.13 and 2.14. Under ideal conditions, energy generated by the source should be totally transferred to the radiation resistance R_r , which is used to represent radiation by the antenna. However, in a practical system there are conduction-dielectric losses due to the lossy nature of the transmission line and the antenna, as well as those due to reflections (mismatch) losses at the interface between the line and the antenna. Taking into account the internal impedance of the source and neglecting line and reflection (mismatch) losses, maximum power is delivered to the antenna under *conjugate matching*. This is discussed in Section 2.13.

The reflected waves from the interface create, along with the traveling waves from the source toward the antenna, constructive and destructive interference patterns, referred to as *standing waves*, inside the transmission line which represent pockets of energy concentrations and storage, typical of resonant devices. A typical standing wave pattern is shown dashed in Figure 1.2, while another is exhibited in Figure 1.15. If the antenna system is not properly designed, the transmission line

**IEEE Transactions on Antennas and Propagation*, vols. AP-17, No. 3, May 1969; AP-22, No. 1, January 1974; and AP-31, No. 6, Part II, November 1983.

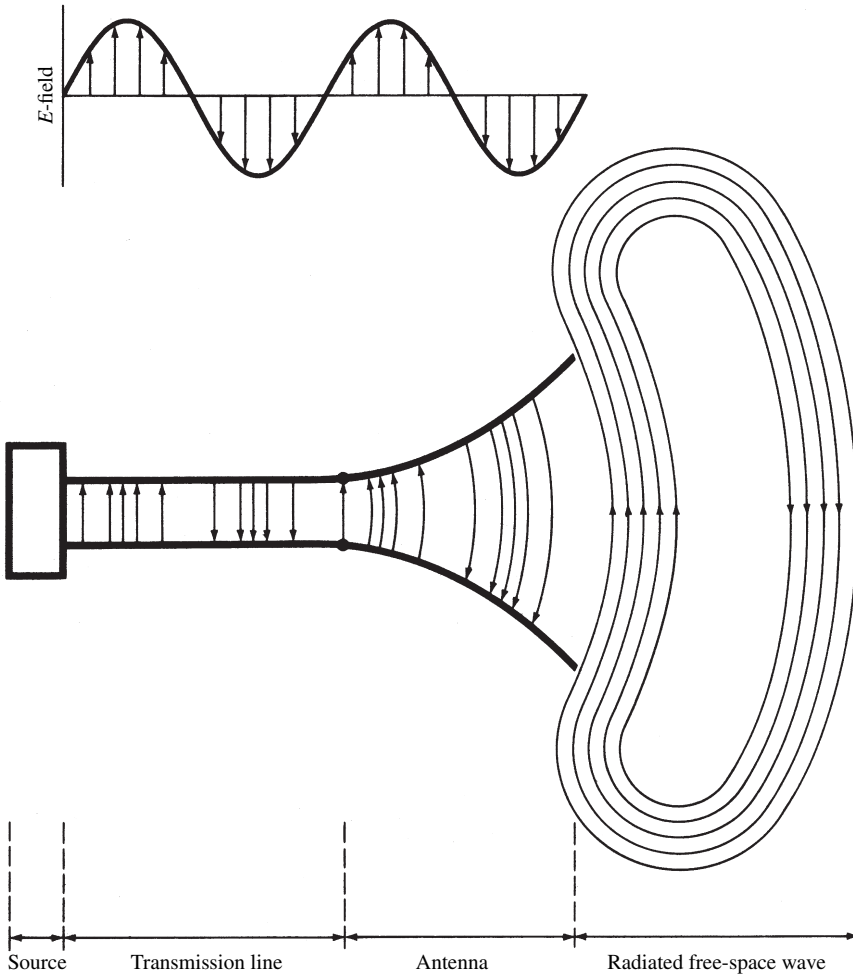

Figure 1.1 Antenna as a transition device.

could act to a large degree as an energy storage element instead of as a wave guiding and energy transporting device. If the maximum field intensities of the standing wave are sufficiently large, they can cause arcing inside the transmission lines.

The losses due to the line, antenna, and the standing waves are undesirable. The losses due to the line can be minimized by selecting low-loss lines while those of the antenna can be decreased by

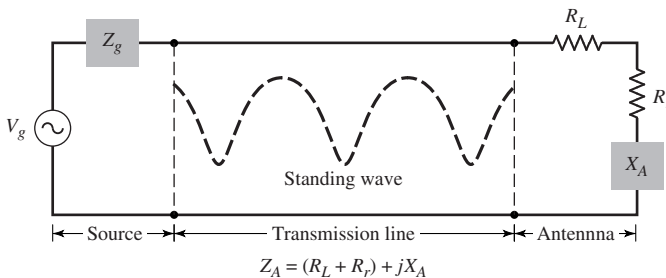

Figure 1.2 Transmission-line Thevenin equivalent of antenna in transmitting mode.

reducing the loss resistance represented by R_L in Figure 1.2. The standing waves can be reduced, and the energy storage capacity of the line minimized, by matching the impedance of the antenna (load) to the characteristic impedance of the line. This is the same as matching loads to transmission lines, where the load here is the antenna, and is discussed more in detail in Section 9.7. An equivalent similar to that of Figure 1.2 is used to represent the antenna system in the receiving mode where the source is replaced by a receiver. All other parts of the transmission-line equivalent remain the same. The radiation resistance R_r is used to represent in the receiving mode the transfer of energy from the free-space wave to the antenna. This is discussed in Section 2.13 and represented by the Thevenin and Norton circuit equivalents of Figure 2.27.

In addition to receiving or transmitting energy, an antenna in an advanced wireless system is usually required to *optimize* or *accentuate* the radiation energy in some directions and suppress it in others. *Thus the antenna must also serve as a directional device in addition to a probing device.* It must then take various forms to meet the particular need at hand, and it may be a piece of conducting wire, an aperture, a patch, an assembly of elements (array), a reflector, a lens, and so forth.

For wireless communication systems, the antenna is one of the most critical components. A good design of the antenna can relax system requirements and improve overall system performance. A typical example is the TV for which the overall broadcast reception can be improved by utilizing a high-performance antenna. The antenna serves to a communication system the same purpose that eyes and eyeglasses serve to a human.

The field of antennas is vigorous and dynamic, and over the last 60 years antenna technology has been an indispensable partner of the communications revolution. Many major advances that occurred during this period are in common use today; however, many more issues and challenges are facing us today, especially since the demands for system performances are even greater. Many of the major advances in antenna technology that have been completed in the 1970s through the early 1990s, those that were under way in the early 1990s, and signals of future discoveries and breakthroughs were captured in a special issue of the *Proceedings of the IEEE* (Vol. 80, No. 1, January 1992) devoted to Antennas. The introductory paper of this special issue [1] provides a carefully structured, elegant discussion of the fundamental principles of radiating elements and has been written as an introduction for the nonspecialist and a review for the expert.

1.2 TYPES OF ANTENNAS

We will now introduce and briefly discuss some forms of the various antenna types in order to get a glance as to what will be encountered in the remainder of the book.

1.2.1 Wire Antennas

Wire antennas are familiar to the layman because they are seen virtually everywhere—on automobiles, buildings, ships, aircraft, spacecraft, and so on. There are various shapes of wire antennas such as a straight wire (dipole), loop, and helix which are shown in Figure 1.3. Loop antennas need not only be circular. They may take the form of a rectangle, square, ellipse, or any other configuration. The circular loop is the most common because of its simplicity in construction. Dipoles are discussed in more detail in Chapter 4, loops in Chapter 5, and helices in Chapter 10.

1.2.2 Aperture Antennas

Aperture antennas may be more familiar to the layman today than in the past because of the increasing demand for more sophisticated forms of antennas and the utilization of higher frequencies. Some forms of aperture antennas are shown in Figure 1.4. Antennas of this type are very useful for aircraft and spacecraft applications, because they can be very conveniently flush-mounted on the skin of

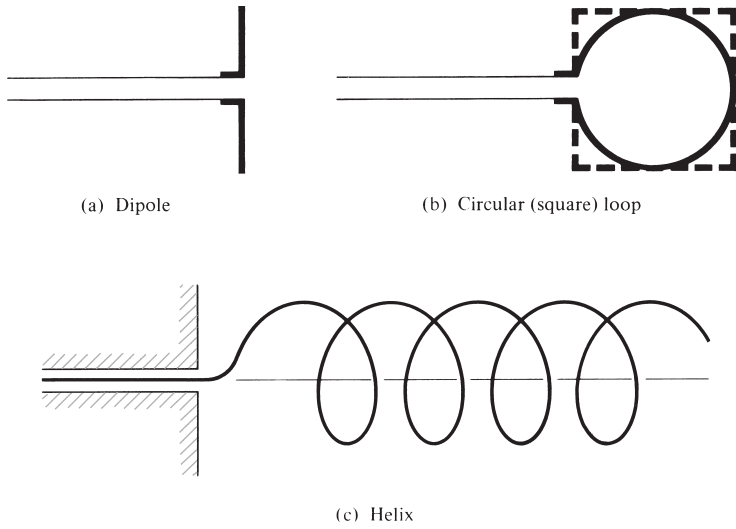
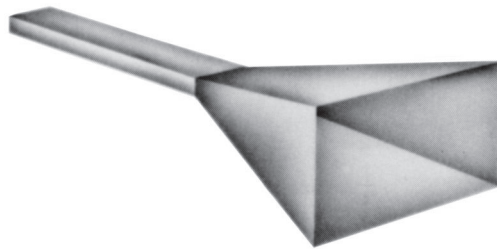

Figure 1.3 Wire antenna configurations.



(a) Pyramidal horn



(b) Conical horn

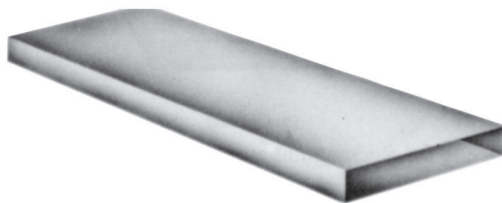

(c) Rectangular waveguide

Figure 1.4 Aperture antenna configurations.

the aircraft or spacecraft. In addition, they can be covered with a dielectric material to protect them from hazardous conditions of the environment. Waveguide apertures are discussed in more detail in Chapter 12 while horns are examined in Chapter 13.

1.2.3 Microstrip Antennas

Microstrip antennas became very popular in the 1970s primarily for spaceborne applications. Today they are used for government and commercial applications. These antennas consist of a metallic patch on a grounded substrate. The metallic patch can take many different configurations, as shown in Figure 14.2. However, the rectangular and circular patches, shown in Figure 1.5, are the most popular because of ease of analysis and fabrication, and their attractive radiation characteristics, especially low cross-polarization radiation. The microstrip antennas are low profile, conformable to planar and nonplanar surfaces, simple and inexpensive to fabricate using modern printed-circuit technology, mechanically robust when mounted on rigid surfaces, compatible with MMIC designs, and very versatile in terms of resonant frequency, polarization, pattern, and impedance. These antennas can be mounted on the surface of high-performance aircraft, spacecraft, satellites, missiles, cars, and even mobile devices. They are discussed in more detail in Chapter 14.

1.2.4 Array Antennas

Many applications require radiation characteristics that may not be achievable by a single element. It may, however, be possible that an aggregate of radiating elements in an electrical and geometrical

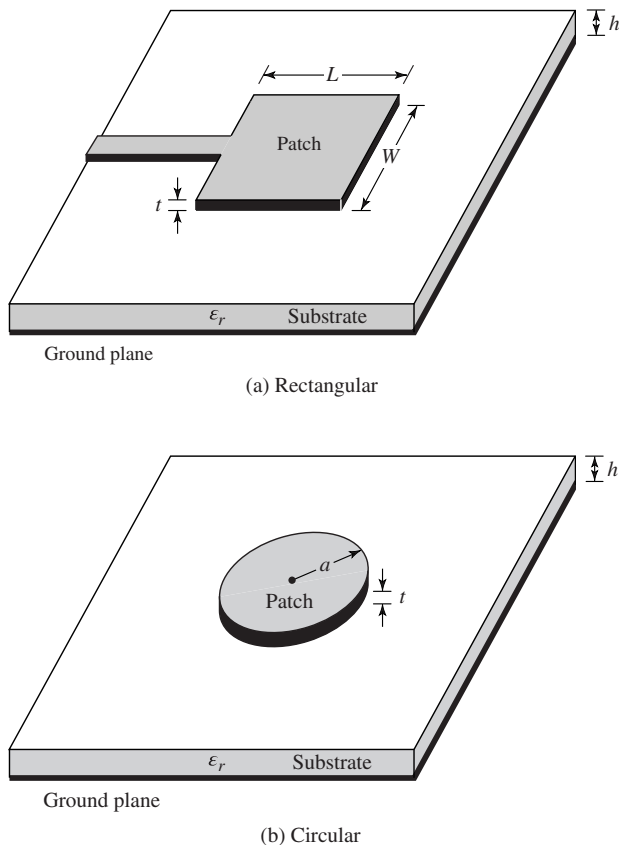

Figure 1.5 Rectangular and circular microstrip (patch) antennas.

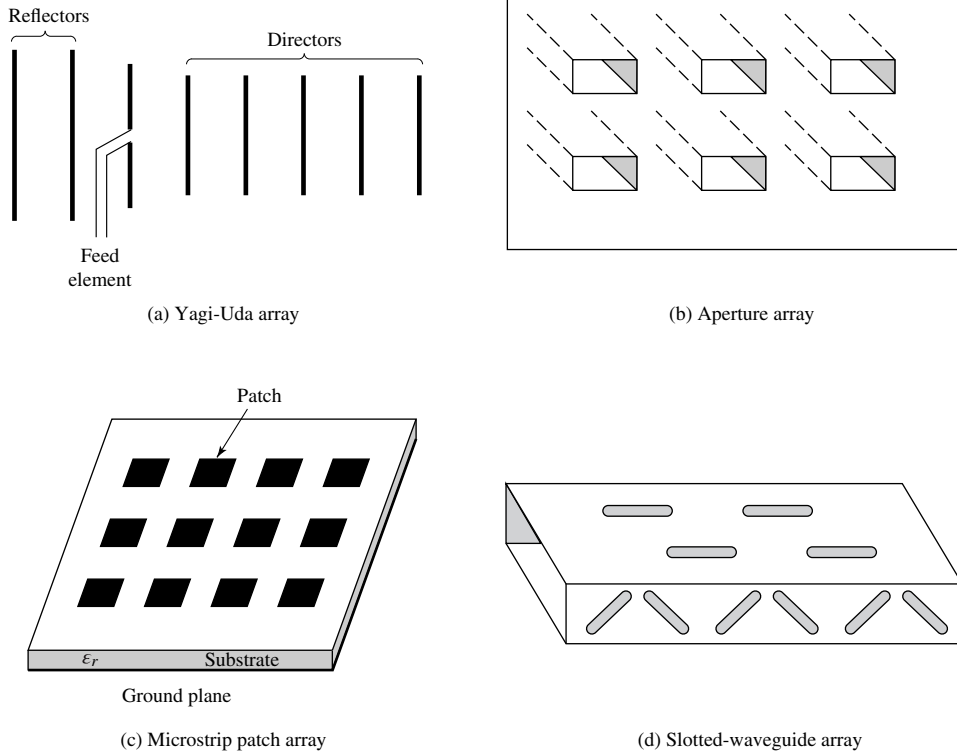

Figure 1.6 Typical wire, aperture, and microstrip array configurations.

arrangement (*an array*) will result in the desired radiation characteristics. The arrangement of the array may be such that the radiation from the elements adds up to give a radiation maximum in a particular direction or directions, minimum in others, or otherwise as desired. Typical examples of arrays are shown in Figure 1.6. Usually the term *array* is reserved for an arrangement in which the individual radiators are separate as shown in Figures 1.6(a–c). However the same term is also used to describe an assembly of radiators mounted on a continuous structure, shown in Figure 1.6(d).

1.2.5 Reflector Antennas

The success in the exploration of outer space has resulted in the advancement of antenna theory. Because of the need to communicate over great distances, sophisticated forms of antennas had to be used in order to transmit and receive signals that had to travel millions of miles. A very common antenna form for such an application is a parabolic reflector shown in Figures 1.7(a) and (b). Antennas of this type have been built with diameters of 305 m or even larger. Such large dimensions are needed to achieve the high gain required to transmit or receive signals after millions of miles of travel. Another form of a reflector, although not as common as the parabolic, is the corner reflector, shown in Figure 1.7(c). These antennas are examined in detail in Chapter 15.

1.2.6 Lens Antennas

Lenses are primarily used to collimate incident divergent energy to prevent it from spreading in undesired directions. By properly shaping the geometrical configuration and choosing the appropriate material of the lenses, they can transform various forms of divergent energy into plane waves. They can be used in most of the same applications as are the parabolic reflectors, especially at

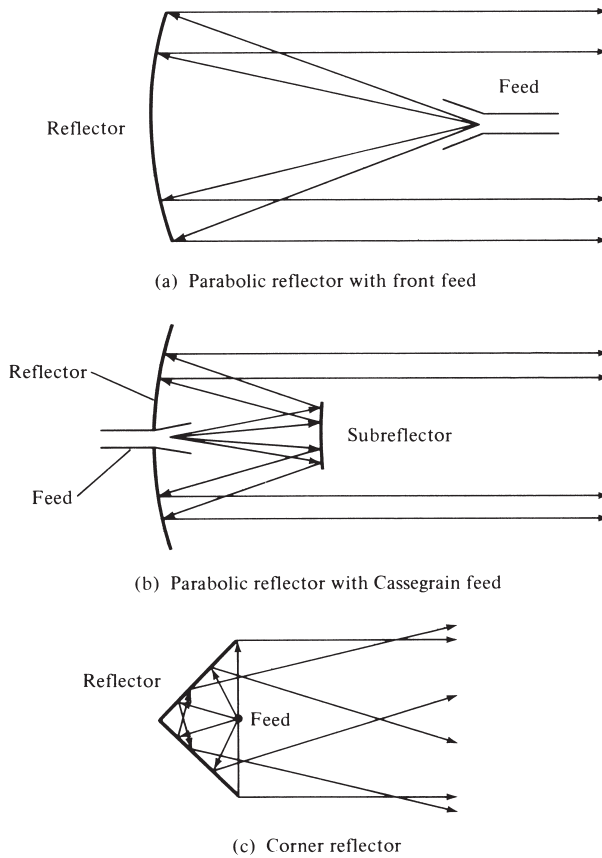

Figure 1.7 Typical reflector configurations.

higher frequencies. Their dimensions and weight become exceedingly large at lower frequencies. Lens antennas are classified according to the material from which they are constructed, or according to their geometrical shape. Some forms are shown in Figure 1.8 [2].

In summary, an ideal antenna is one that will radiate all the power delivered to it from the transmitter in a desired direction or directions. In practice, however, such ideal performances cannot be achieved but may be closely approached. Various types of antennas are available and each type can take different forms in order to achieve the desired radiation characteristics for the particular application. Throughout the book, the radiation characteristics of most of these antennas are discussed in detail.

1.3 RADIATION MECHANISM

One of the first questions that may be asked concerning antennas would be “how is radiation accomplished?” In other words, how are the electromagnetic fields generated by the source, contained and guided within the transmission line and antenna, and finally “detached” from the antenna to form a free-space wave? The best explanation may be given by an illustration. However, let us first examine some basic sources of radiation.

1.3.1 Single Wire

Conducting wires are material whose prominent characteristic is the motion of electric charges and the creation of current. Let us assume that an electric volume charge density, represented by q_v ,

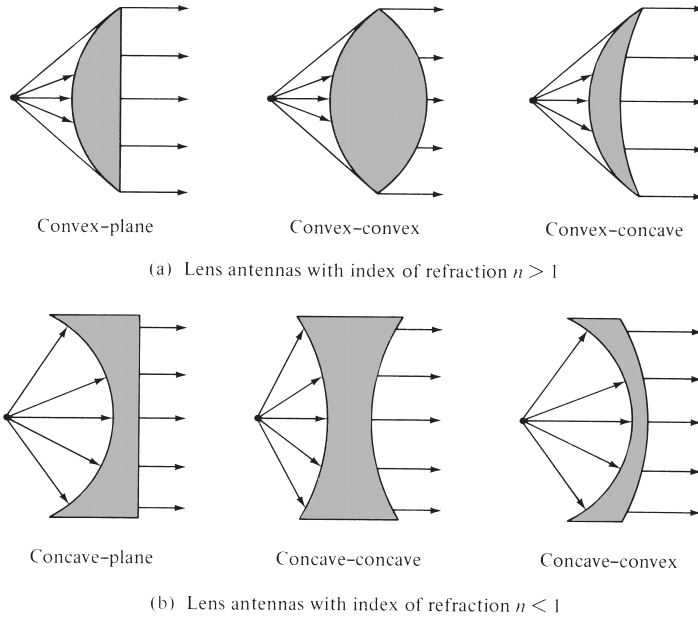

Figure 1.8 Typical lens antenna configurations. (SOURCE: L. V. Blake, *Antennas*, Wiley, New York, 1966).

(coulombs/m³), is distributed uniformly in a circular wire of cross-sectional area A and volume V , as shown in Figure 1.9. The total charge Q within volume V is moving in the z direction with a uniform velocity v_z (meters/sec). It can be shown that the current density J_z (amperes/m²) over the cross section of the wire is given by [3]

$$J_z = q_v v_z \tag{1-1a}$$

If the wire is made of an ideal electric conductor, the current density J_s (amperes/m) resides on the surface of the wire and it is given by

$$J_s = q_s v_z \tag{1-1b}$$

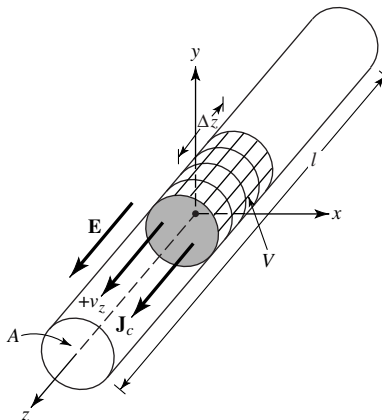

Figure 1.9 Charge uniformly distributed in a circular cross section cylinder wire.

where q_s (coulombs/m²) is the surface charge density. If the wire is very thin (ideally zero radius), then the current in the wire can be represented by

$$I_z = q_l v_z \quad (1-1c)$$

where q_l (coulombs/m) is the charge per unit length.

Instead of examining all three current densities, we will primarily concentrate on the very thin wire. The conclusions apply to all three. If the current is time varying, then the derivative of the current of (1-1c) can be written as

$$\frac{dI_z}{dt} = q_l \frac{dv_z}{dt} = q_l a_z \quad (1-2)$$

where $dv_z/dt = a_z$ (meters/sec²) is the acceleration. If the wire is of length l , then (1-2) can be written as

$$l \frac{dI_z}{dt} = l q_l \frac{dv_z}{dt} = l q_l a_z \quad (1-3)$$

Equation (1-3) is the basic relation between current and charge, and it also serves as the fundamental relation of electromagnetic radiation [4], [5]. It simply states that *to create radiation, there must be a time-varying current or an acceleration (or deceleration) of charge*. We usually refer to currents in time-harmonic applications while charge is most often mentioned in transients. To create charge acceleration (or deceleration) the wire must be curved, bent, discontinuous, or terminated [1], [4]. Periodic charge acceleration (or deceleration) or time-varying current is also created when charge is oscillating in a time-harmonic motion, as shown in Figure 1.17 for a $\lambda/2$ dipole. Therefore:

1. If a charge is not moving, current is not created and there is no radiation.
2. If charge is moving with a uniform velocity:
 - a. There is no radiation if the wire is straight, and infinite in extent.
 - b. There is radiation if the wire is curved, bent, discontinuous, terminated, or truncated, as shown in Figure 1.10.
3. If charge is oscillating in a time-motion, it radiates even if the wire is straight.

A qualitative understanding of the radiation mechanism may be obtained by considering a pulse source attached to an open-ended conducting wire, which may be connected to the ground through a discrete load at its open end, as shown in Figure 1.10(d). When the wire is initially energized, the charges (free electrons) in the wire are set in motion by the electrical lines of force created by the source. When charges are accelerated in the source-end of the wire and decelerated (negative acceleration with respect to original motion) during reflection from its end, it is suggested that radiated fields are produced at each end and along the remaining part of the wire, [1], [4]. *Stronger radiation with a more broad frequency spectrum occurs if the pulses are of shorter or more compact duration while continuous time-harmonic oscillating charge produces, ideally, radiation of single frequency determined by the frequency of oscillation.* The acceleration of the charges is accomplished by the external source in which forces set the charges in motion and produce the associated field radiated. The deceleration of the charges at the end of the wire is accomplished by the internal (self) forces associated with the induced field due to the buildup of charge concentration at the ends of the wire. The internal forces receive energy from the charge buildup as its velocity is reduced to zero at the ends of the wire. Therefore, charge acceleration due to an exciting electric field and deceleration due